

The N-TRON® 702-W Industrial Wireless Radio offers outstanding performance and ease of use. It is ideally suited for connecting wireless devices to a wired network or for connecting two wired networks where it is not possible, impractical, or too expensive to install cable.

Product Features

- Full IEEE 802.11a,b,g,n Compliance
- One 10/100BaseTX RJ-45 Port
- Three Antennas for 3x3 MIMO Operations
- Four user definable LED's for display of signal quality
- Radio Enable, Link/Activity, and power LEDs
- 802.3af PoE Powered Device
- Extended Environmental Specifications
- Autosensing 10/100BaseTX, Duplex, and MDIX
- Rugged DIN Rail Enclosure
- Redundant Power Inputs (20-49 VDC)
- Web Browser Management

Wireless Compliance:

- IEEE 802.11a Compliant
- IEEE 802.11b Compliant
- IEEE 802.11g Compliant
- IEEE 802.11n draft Compliant

Security

- 802.11i with AES-CCM & TKIP Encryption
- 802.1x, 64/128 bit WEP

Data Rates:

- Legacy 802.11a/b/g (1-54Mbps)
- 802.11n (up to 300Mbps)

Range Performance:

- Indoor (Antenna Dependent) greater than 300m
- Outdoor (Antenna Dependent) greater than 60km

Applications

In industrial environments, situations arise where the installation of fiber or Cat5e cable and associated power cables is difficult or cost prohibitive. There are also applications which require communications with mobile devices such as forklifts, cockpits on cranes, laptop computers, and other devices that are impossible to connect with copper or fiber cable. The N-TRON® 702-W provides a wireless connection that can be quickly and easily deployed. With it's wide operating temperature range and 1 million hour MTBF, the 702-W offers the industrial ruggedness that customers have come to expect of N-TRON products. Three antennas allows the 702-W to utilize Multiple In, Multiple Out (MIMO) technology for increased throughput. Power over Ethernet (PoE) technology enables the 702-W to receive power through Cat5e cable from a PoE sourcing device, such as the N-TRON 105TX-POE Switch or the 100-PoE4 Midspan. Temporary deployments of network nodes are much easier using wireless and PoE technology because only one Cat5e cable is required.



Industrial Packaging and Specifications

The is specifically designed to operate in industrial environments. With it's rugged enclosure and industrial specifications such as extended shock and vibrations specs plus redundant power inputs, the 702-W easily meets and exceeds the operating parameters of the connected equipment.

Multiple Wireless Modes

The 702-W provides a number of configuration options to allow it to be customized to suit specific application requirements.

Station: In "station" configuration the 702-W is used to connect a single device (MAC Address) to a wireless access point.

Station, WDS (Wireless Distribution System): In "station, WDS" mode the 702-W can be connected to a remote wired switch and will allow multiple devices (MAC Address forwarding) to be connected to the wireless access point with WDS activated.

Access Point: The "Access Point" mode allows the 702-W to serve as a wireless switch for the attached wireless stations. Wireless access points are commonly used to create one wireless local area network (WLAN) that spans an area around the Access Point. Each access point typically supports up to 253 stations.

Access Point, WDS (Wireless Distribution System): The 702-W in "Access Point, WDS" mode allows wireless connection of a number of access points to extend the coverage of the wireless network. The main base Access Point in WDS mode is extended using a series of relay access points in WDS mode (Extended Service Set) and can in turn form a WLAN consisting of thousands of stations. All stations should be configured in "Station WDS" mode. Correctly configured switches using WDS will create a single network, providing station mobility throughout the wireless network.

Multiple Network Modes

Bridge: In this mode the 702-W will operate in layer two without network segmentation.

Router: Router operating mode offers layer three routing to allow network segmentation.

Scenario 1 – Basic Bridge

Access Point:

The "Access Point" mode allows the 702-W to serve as a wireless switch for the wireless stations attached to it. Wireless access points are commonly used to create one wireless local area network (WLAN) that spans an area around the Access Point. Each access point typically supports up to 253 stations.

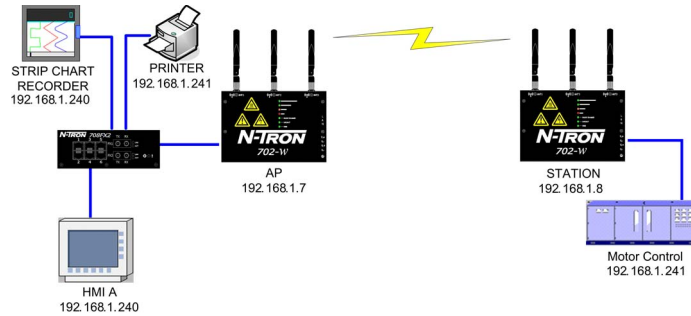

Station:

In "station" configuration the 702-W is used to connect a single device (MAC Address) to a wireless access point.

For added security, the 702-W supports WEP, WPA™, and WPA2™. WPA and WPA2, TKIP (Temporal Key Integrity Protocol) and CCMP (Counter Mode with Cipher Block Chaining Message Authentication Code Protocol) are available.

Scenario 2 – Control Network

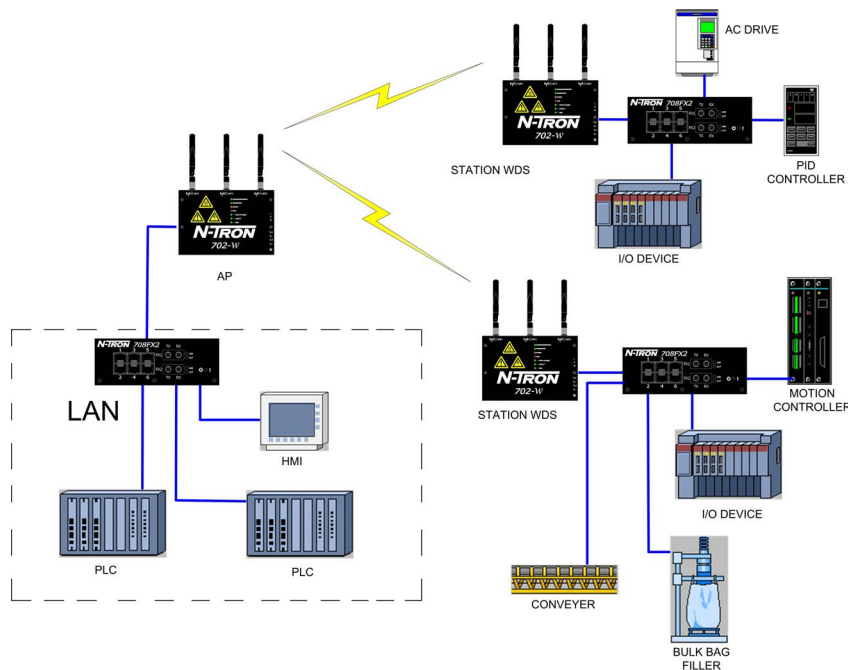

In Station WDS mode the 702-W can be connected to a remote wired Ethernet switch with multiple devices connected to the switch.

Scenario 3 – WDS Peering

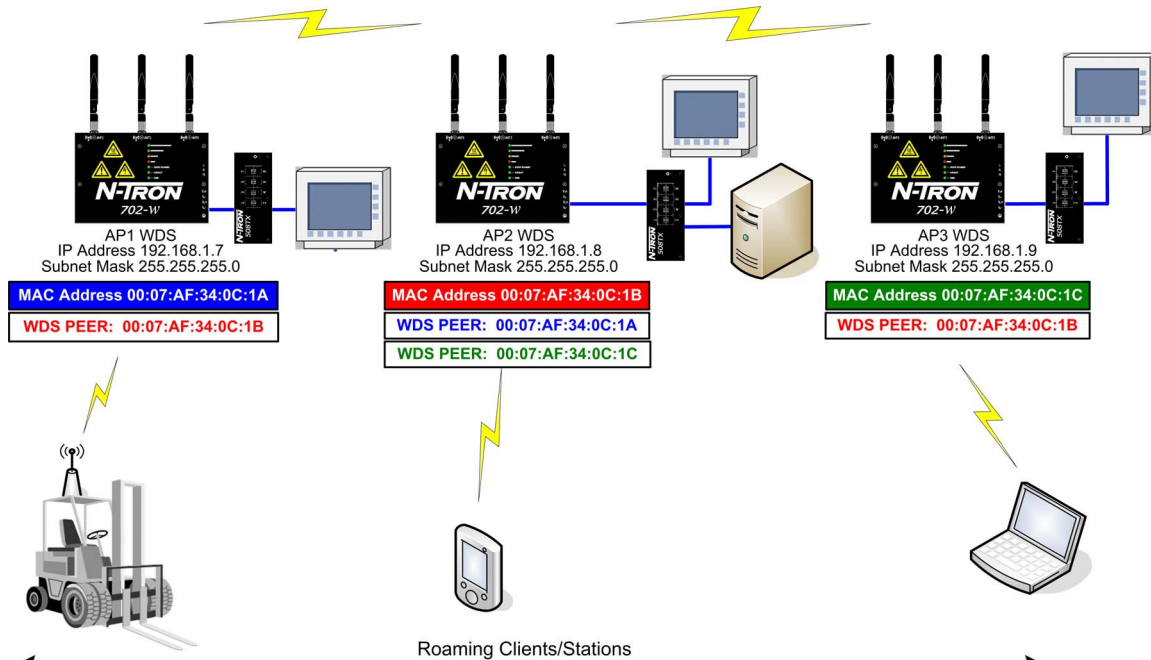

The 702-Ws have been configured as peers. This allows forklifts or other mobile wireless device to maintain communication as they move from the area covered by one 702-W into the area covered by the next 702-W.

Scenario 4 – Broadband Modem Wireless Router (W/ DHCP)

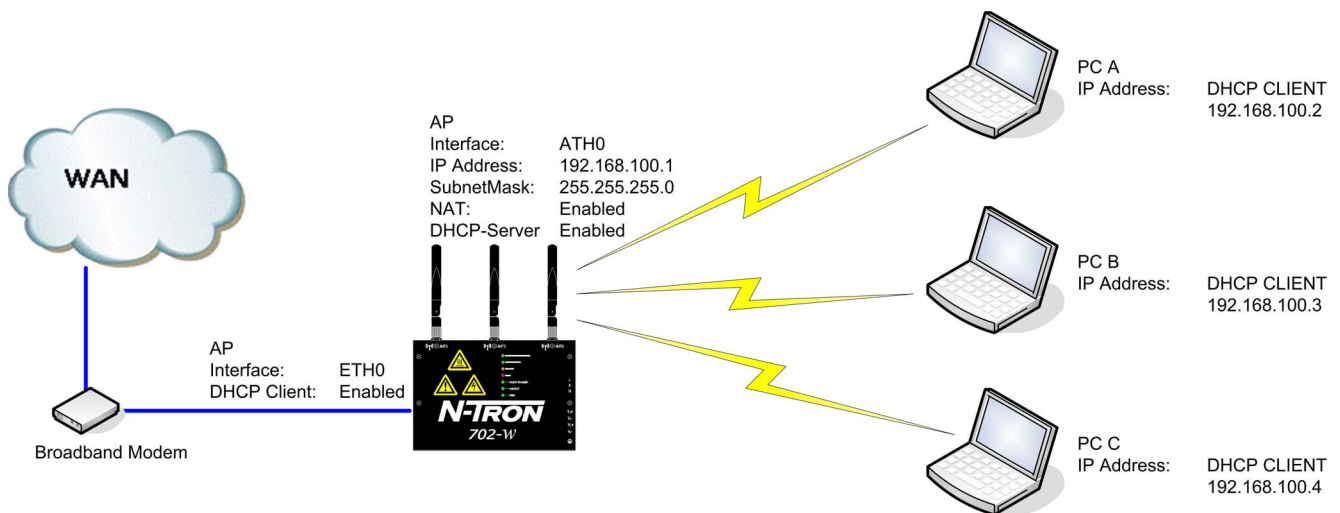

N-TRON 702-W configured as a powered Router allows layer 3 routing to set up network segmentation. It supports the Network Address Translation (Masquerading) feature which is widely used by Access Points. NAT will act as the firewall between LAN and WLAN networks. Additional Firewall settings can be configured for Layer 3 packet filtering and access control in Router mode. It can also act as a DHCP server, automating the assigning of IP addresses.

702-W Specifications

Physical

Height: (w/o antennas)	5.2"	(13.2cm)
Width:	7.4"	(18.8cm)
Depth (incl. DIN-Rail mount):	1.5"	(3.81cm)
Weight (max):	1.9 lbs	(0.86kg)
DIN-Rail Mount:	35mm	

Environmental

Operating Temperature:	-40°C to 70°C	
Storage Temperature:	-40°C to 85°C	
Operating Humidity:	5% to 95% (Non Condensing)	
Operating Altitude:	0 to 10,000 ft.	
N-TRON Power Supply:	NTPS-24-1.3	

Electrical

Redundant Input Voltage:	20-49 VDC (Regulated)
Input Current (max):	200mA max @24 VDC
702-W Max Power:	4.8Watts max
Input Ripple:	Less than 100mV

Reliability

MTBF:	>1 Million Hours
-------	------------------

Network Media

10BaseT:	>Cat3 Cable
100BaseTX:	>Cat5 Cable
802.11abgn:	Air

Connectors

10/100BaseTX:	One (1) RJ-45 Copper Port PoE Powered device support
802.11abgn	(3) RP-SMA connectors

Recommended Wiring Clearance (Antenna Dependent)

Front:	4" (10.16cm)
Side:	4" (10.16cm)
Top:	6" (15.24cm)

702-W WIRELESS ETHERNET RADIO

Ordering Information

702-W	Industrial Wireless Radio
702-W-PM	Panel Mount Kit for 702-W
ANT-CAB-400-N-RPSMA-X	Low Loss Coaxial Antenna cable; 1 RP-SMA and 1 N Male connector
ANT-MD24-12	2.4GHz 12dBi Mini Directional Antenna
ANT-PAD24-16	2.4GHz 16dBi Directional Antenna
ANT-PAD58-19	5.8GHz 19dBi Directional Antenna
ANT-PAD58-32	5.8 GHz Parabolic Dish 32dBi Directional Antenna
NTPS-24-1.3	DIN-Rail Power Supply 24V@1.3 Amp

Radio Output Power:

Up to 250mW US

802.11a 5GHz	DataRate	Avg TX ±2dB
	1-24Mbps	24 dBm
	36Mbps	22 dBm
	48Mbps	20 dBm
	54Mbps	19 dBm

802.11b/g 2.4GHz	DataRate	Avg TX ±2dB
	1-24Mbps	24 dBm
	36Mbps	22 dBm
	48Mbps	20 dBm
	54Mbps	19 dBm

802.11n 2.4GHz 5GHz	DataRate	Avg TX ±2dB
	MCS0	24dBm 24dBm
	MCS1	24dBm 24dBm
	MCS2	24dBm 24dBm
	MCS3	22dBm 22dBm
	MCS4	22dBm 22dBm
	MCS5	22dBm 22dBm
	MCS6	18dBm 18dBm
	MCS7	15dBm 15dBm
	MCS8	24dBm 24dBm
	MCS9	24dBm 24dBm
	MCS10	22dBm 22dBm
	MCS11	20dBm 20dBm
	MCS12	20dBm 20dBm
	MCS13	17dBm 17dBm
	MCS14	17dBm 17dBm
	MCS15	15dBm 15dBm

Radio Receiver Sensitivity

802.11a 5GHz	DataRate	Sens. ±3dB
	1-24Mbps	-96 dBm
	36Mbps	-95 dBm
	48Mbps	-84 dBm
	54Mbps	-91 dBm

802.11b/g 2.4GHz	DataRate	Sens. ±3dB
	1-24Mbps	-97 dBm
	36Mbps	-90 dBm
	48Mbps	-86 dBm
	54Mbps	-84 dBm

802.11n 2.4GHz 5GHz	DataRate	Sens. ±3dB
	MCS0	-97dBm -96dBm
	MCS1	-96dBm -95dBm
	MCS2	-93dBm -92dBm
	MCS3	-91dBm -90dBm
	MCS4	-87dBm -86dBm
	MCS5	-84dBm -83dBm
	MCS6	-78dBm -77dBm
	MCS7	-75dBm -74dBm
	MCS8	-96dBm -95dBm
	MCS9	-94dBm -93dBm
	MCS10	-91dBm -90dBm
	MCS11	-88dBm -87dBm
	MCS12	-85dBm -84dBm
	MCS13	-80dBm -79dBm
	MCS14	-79dBm -78dBm
	MCS15	-76dBm -75dBm

Regulatory Approvals

UL /cUL Class I, Div 2, Groups A, B, C, D, and T4A
ANSI/ISA-12.12.01-2007 and UL 508 and 1604
FCC/CE (CFR 47, Part 15, Subpart B - Class A)
EN 301 489-3, IEC 6100-4-2, 6100-4-3,
R&TTE Directive 99/5/EC, ANSI C63.4, and ICES-003 Issue 3
GOST-R Certified, RoHS Compliant
Designed to comply with:
IEEE 1613 for Electric Utility Substations
NEMA TS1/ TS2 for Traffic control

Contact Information

N-TRON Corp.
820 S. University Blvd., Suite 4E
Mobile, AL 36609 USA
TEL: (251) 342-2164
FAX: (251) 342-6353
Website: www.n-tron.com
Email: N-TRON_info@n-tron.com

N-TRON Europe GmbH
Alte Steinhäuserstr 19
6330 Cham / Zg Switzerland
TEL: +41 41 7406636
FAX: +41 41 7406637

