

The N-TRON® 702M12-W Industrial Wireless Radio offers outstanding performance and ease of use. It is ideally suited for connecting wireless devices to a wired network or for connecting two wired networks in an IP67 environment, where it is not possible, impractical, or too expensive to install cable.

Product Features

- Full IEEE 802.11a,b,g,n Compliance
- IP67 Rated, Industrial Hardened Enclosure
- One 10/100BaseTX M12 Port
- Three Antennas for 3x3 MIMO Operations
- Four user definable LED's for display of signal quality
- Radio Enable, Link/Activity, and power LEDs
- 802.3af PoE Powered Device
- Extended Environmental Specifications
- Autosensing 10/100BaseTX, Duplex, and MDIX
- Redundant Power Inputs (20-49 VDC)
- Web Browser Management

Wireless Compliance:

- IEEE 802.11a/b/g/n Compliant

Security:

- 802.11i with AES-CCM & TKIP Encryption
- 802.1x, 64/128 bit WEP

Data Rates:

- Legacy 802.11a/b/g (1-54Mbps),
- 802.11n (up to 300Mbps)

Range Performance:

- Indoor (Antenna Dependent) greater than 300m
- Outdoor (Antenna Dependent) greater than 60km

Applications

In industrial environments, the installation of fiber or Cat5e cable and associated power cables is difficult or cost prohibitive. There are also applications which require communication with mobile devices such as laptop computers, forklifts, cockpits or control centers on mobile equipment such as cranes, and other devices which are impossible to connect with copper or fiber cable. The N-TRON 702M12-W provides a wireless connection that can be quickly and easily deployed. With it's wide operating temperature range and 1 million hours MTBF, the 702M12-W offers the industrial ruggedness that customers have come to expect of N-TRON products. The IP67 sealed enclosure insures that outdoor, wash down, and the most dusty environments will present no problems to the 702M12-W. Three antennas enable the use of Multiple-In, Multiple-Out (MIMO) technology for increased throughput. Power over Ethernet (PoE) technology allows the 702M12-W to receive power through the Cat5e cable from a PoE sourcing device, such as the N-TRON 105TX-POE Switch. This eliminates the need for power cables or power supplies for the 702M12-W. Using wireless and PoE technology makes temporary deployment of network nodes much easier because only one Cat5e cable is required.



Industrial Packaging and Specifications

The 702M12-W is specifically designed to operate in industrial environments. With it's rugged enclosure and industrial specifications such as extended shock and vibrations specs plus redundant power inputs, the 702M12-W easily meets and exceeds the operating parameters of the connected equipment.

Multiple Wireless Modes

The 702M12-W provides a number of configuration options that allow it to be customized to suit specific application requirements.

Station: In "station" configuration the 702M12-W is used to connect a single device (MAC Address) to a wireless access point.

Station, WDS (Wireless Distribution System): In "station, WDS" mode the 702M12-W can be connected to a remote wired switch and will allow multiple devices (MAC Address forwarding) to be connected to the wireless access point with WDS activated.

Access Point: The "Access Point" mode allows the 702M12-W to serve as a wireless switch for the attached wireless stations. Wireless access points are commonly used to create one wireless local area network (WLAN) that spans an area around the Access Point. Each access point typically supports up to 253 stations.

Access Point, WDS (Wireless Distribution System): The 702M12-W in "Access Point, WDS" mode allows wireless connection of a number of access points to extend the coverage of the wireless network. The main base Access Point in WDS mode is extended using a series of relay Access points in WDS mode (Extended Service Set) and can in turn form a WLAN consisting of thousands of stations. All stations should be configured in "Station WDS" mode. Correctly configured switches using WDS will create a single network, providing station mobility throughout the wireless network.

Multiple Network Modes

Bridge: In this mode the 702M12-W will operate in Layer two without network segmentation.

Router: Router operating mode offers Layer three routing to allow network segmentation.

Scenario 1 – Basic Bridge

Access Point:

The "Access Point" mode allows the 702M12-W to serve as a wireless switch for the wireless stations attached to it.

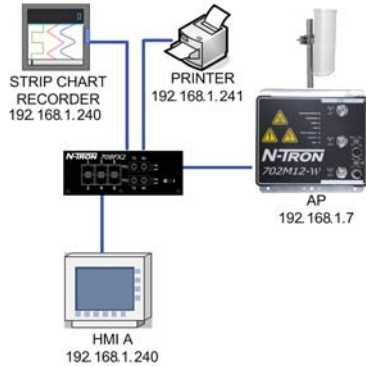

Station:

In "station" configuration the 702M12-W is used to connect a single device (MAC Address) to a wireless access point.



For added security, the 702M12-W supports WEP, WPA™, and WPA2™. WPA and WPA2, TKIP (Temporal Key Integrity Protocol) and CCMP (Counter Mode with Cipher Block Chaining Message Authentication Code Protocol) are available.

Scenario 2 – Control Network

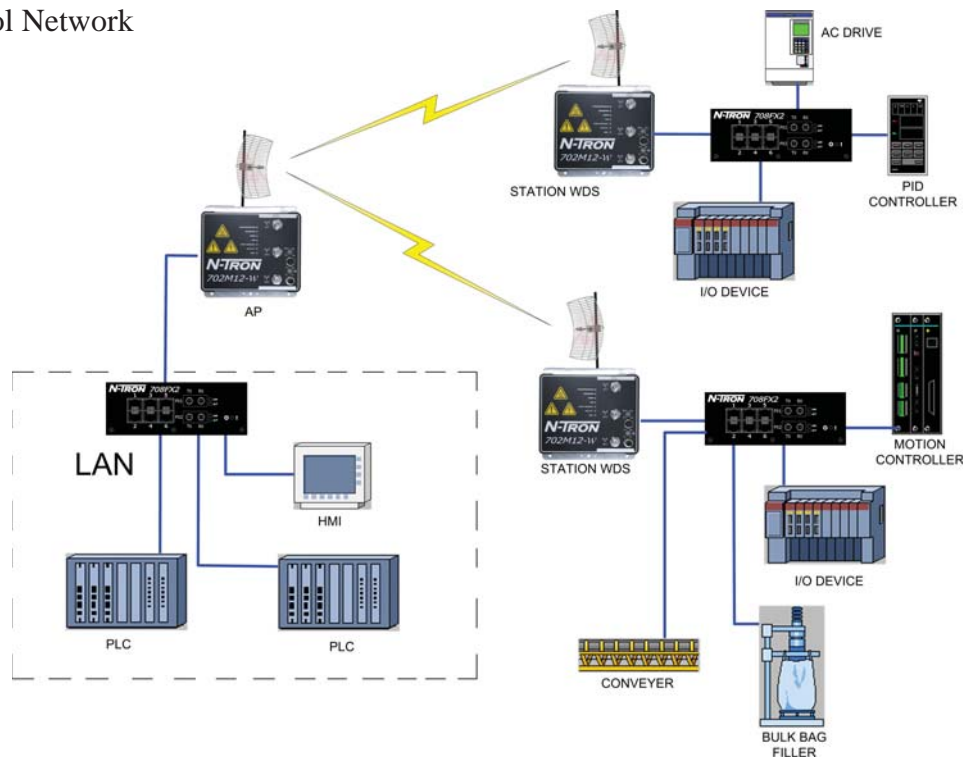

In Station WDS mode the 702M12-W can be connected to a remote wired Ethernet switch with multiple devices connected to the switch.

Scenario 3 – WDS Peering

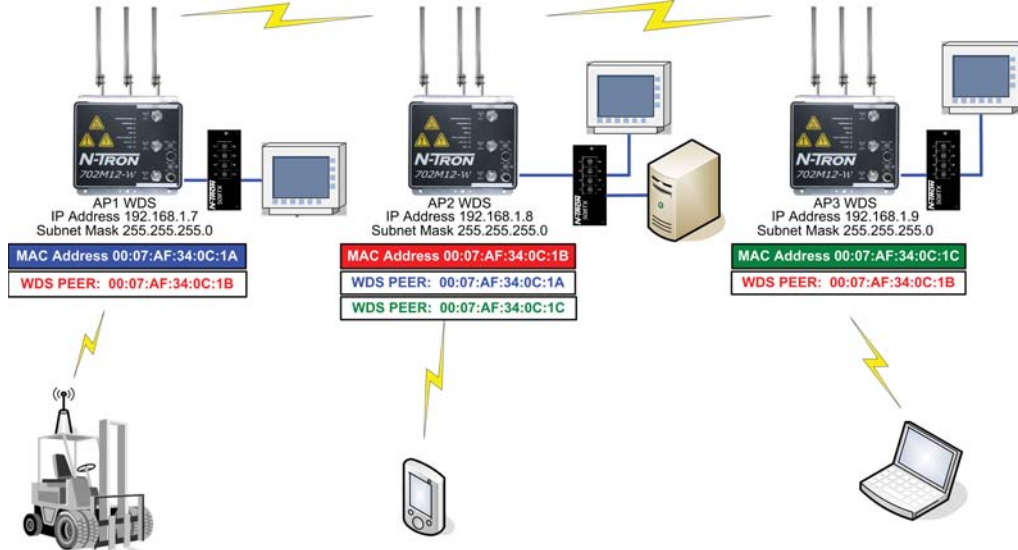

In this scenario, each 702M12-W has been configured as a peer of selected other 702M12-W(s) by using the MAC Addresses of the select unit(s). This allows forklifts or other mobile wireless devices to maintain communication seamlessly as they move from the area covered by one 702M12-W into the area covered by the next 702M12-W.

Scenario 4 – Broadband Modem Wireless Router (W/ DHCP)

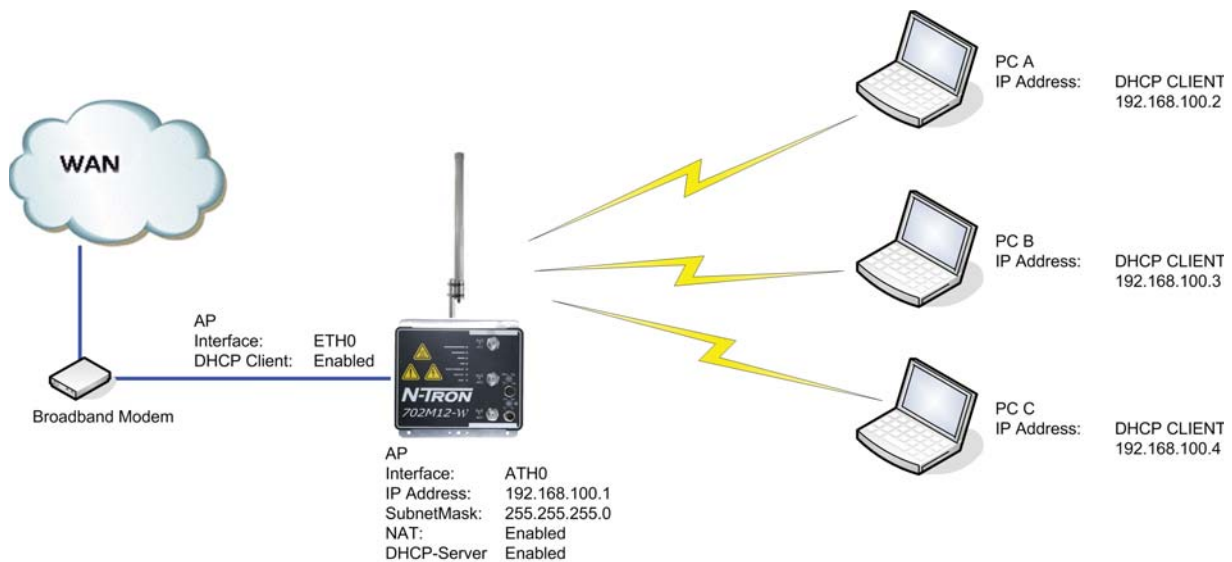

The N-TRON 702M12-W configured as a router can act as a DHCP server and supports the Network Address Translation (Masquerading) feature which is widely used by Access Points. This automates the assigning of IP addresses to devices as they connect. NAT will act as a firewall between LAN and WLAN networks. Additional firewall settings can be configured for layer 3 packet filtering and access control in Router mode.

702M12-W Specifications

Case Dimensions

Height: (w/o antennas)	6.7"	(17.2 cm)
Width:	6.7"	(17.2 cm)
Depth:	1.8"	(4.6 cm)
Weight (max):	3.5 lbs	(1.6 kg)

Environmental

Operating Temperature:	-40°C to 70°C
Storage Temperature:	-40°C to 85°C
Operating Humidity:	5% to 100% (Non Condensing)
Operating Altitude:	0 to 10,000 ft.
N-TRON Power Supply:	NTPS-24-1.3

Electrical

Redundant Input Voltage:	20-49 VDC (Regulated)
Input Current (max):	200mA max @24 VDC
702M12-W Max Power:	4.8Watts max
Input Ripple:	Less than 100mV

Reliability

MTBF:	>1 Million Hours
-------	------------------

Network Media

10BaseT:	>Cat3 Cable
100BaseTX:	>Cat5 Cable
802.11abgn:	Air

Connectors

10/100BaseTX:	One (1) M12 Copper Port PoE Powered device support
802.11abgn	(3) RP-TNC connectors

Recommended Wiring Clearance (Antenna Dependent)

Front:	4" (10.16cm)
Side:	4" (10.16cm)
Top:	6" (15.24cm)

Contact Information

N-TRON Corp.
820 S. University Blvd., Suite 4E
Mobile, AL 36609 USA
TEL: (251) 342-2164
FAX: (251) 342-6353
Website: www.N-TRON.com
Email: N-TRON_info@N-TRON.com

N-TRON Asia
Suite #: 2267, 22/F, One Lujiazui
68 Yin Cheng Road Center,
Pudong New Area
200120 Shanghai, P.R. China
Phone: +86 (0) 21 6194 6777
Fax: +86 (0) 21 6194 6699

N-TRON Europe GmbH
Alte Steinhäuserstr 19
6330 Cham / Zg Switzerland
TEL: +41 41 7406636
FAX: +41 41 7406637

REV 100924

Radio Output Power:

Up to 250mW US

802.11a 5GHz	DataRate	Avg TX ±2dB
1-24Mbps	24 dBm	
36Mbps	22 dBm	
48Mbps	20 dBm	
54Mbps	19 dBm	

802.11b/g 2.4GHz

DataRate	Avg TX ±2dB
1-24Mbps	24 dBm
36Mbps	22 dBm
48Mbps	20 dBm
54Mbps	19 dBm

802.11n 2.4GHz 5GHz

DataRate	Avg TX ±2dB
MCS0	24dBm 24dBm
MCS1	24dBm 24dBm
MCS2	24dBm 24dBm
MCS3	22dBm 22dBm
MCS4	22dBm 22dBm
MCS5	22dBm 22dBm
MCS6	18dBm 18dBm
MCS7	15dBm 15dBm
MCS8	24dBm 24dBm
MCS9	24dBm 24dBm
MCS10	22dBm 22dBm
MCS11	20dBm 20dBm
MCS12	20dBm 20dBm
MCS13	17dBm 17dBm
MCS14	17dBm 17dBm
MCS15	15dBm 15dBm

Radio Receiver Sensitivity

802.11a 5GHz	DataRate	Sens. ±3dB
1-24Mbps	-96 dBm	
36Mbps	-95 dBm	
48Mbps	-94 dBm	
54Mbps	-91 dBm	

802.11b/g 2.4GHz

DataRate	Sens. ±3dB
1-24Mbps	-97 dBm
36Mbps	-90 dBm
48Mbps	-86 dBm
54Mbps	-84 dBm

802.11n 2.4GHz 5GHz

DataRate	Sens. ±3dB
MCS0	-97dBm -96dBm
MCS1	-96dBm -95dBm
MCS2	-93dBm -92dBm
MCS3	-91dBm -90dBm
MCS4	-87dBm -86dBm
MCS5	-84dBm -83dBm
MCS6	-78dBm -77dBm
MCS7	-75dBm -74dBm
MCS8	-96dBm -95dBm
MCS9	-94dBm -93dBm
MCS10	-91dBm -90dBm
MCS11	-88dBm -87dBm
MCS12	-85dBm -84dBm
MCS13	-80dBm -79dBm
MCS14	-79dBm -78dBm
MCS15	-76dBm -75dBm

Regulatory Approvals

UL /cUL Class I, Div 2, Groups A, B, C, D, and T4A
ANSI/ISA-12.12.01-2007 and UL 508 and 1604

FCC/CE (CFR 47, Part 15, Subpart B - Class A),
EN 301 489-3, IEC 6100-4-2, 6100-4-3,
R&TTE Directive 99/5/EC, ANSI C63.4, and ICES-003 Issue 3
GOST-R Certified, RoHS Compliant,

Designed to comply with:

IEEE 1613 for Electric Utility Substations
NEMA TS1/ TS2 for Traffic control

702M12-W WIRELESS ETHERNET RADIO

Ordering Information

702M12-W	Industrial Wireless Radio
702M12-PK	Pole mount kit for 702M12-W
ANT-CAB-400-N-RPTNC-X	Low Loss Coaxial Antenna cable 1 RP-TNC and 1 N Male connector
ANT-MD24-12	2.4GHz 12dBi Mini Directional Antenna
ANT-PAD24-16	2.4GHz 16dBi Directional Antenna
ANT-PAD58-19	5.8GHz 19dBi Directional Antenna
ANT-PD58-32	5.8 GHz Parabolic Dish 32dBi Directional Antenna
ANT-LA6-NFF	2-6GHz quarter wave lightning arrestor (N-female to N-female, less than 0.2dB insertion loss, IP65, -40 to 85°C)
ANT-CAB-400-N-X	Low loss CA-400 coaxial cable with (2) N Female connectors for use with the ANT-LA6-NFF lightning arrestor
M12DRC-ISO	DIN-Rail kit, two isolated plastic clips
M12DRC-MTL	DIN-Rail kit, two metal clips
NTPS-24-1.3	DIN-Rail Power Supply 24V@1.3 Amp

Cables with M12 connectors

Ordering Information

CAT5E-M12-M12-X	Straight M12 to Str. M12, Shielded
CAT5E-M12-RJ45-X	Straight M12 to RJ-45, Shielded
CAT5E-M12-X	Straight M12 to bare end, Shielded
CAT5E-RM12-M12-X	90° M12 to Str. M12, Shielded
CAT5E-RM12-RM12-X	90° M12 to 90° M12, Shielded
CAT5E-RM12-RJ45-X	90° M12 to RJ-45, Shielded
CAT5E-RM12-X	90° M12 to bare end, Shielded
PWR-M12-A-X	Power Cable, M12 A-Coded Straight Female to bare end, Shielded
PWR-RM12-A-X	Power Cable, M12 A-Coded 90° Female to bare end, Shielded

Where: X = length of cable, fill in desired amount in feet.
Example: CAT5E-RM12-10 (for a 10ft cable)

